

Project \_\_\_\_\_ Type \_\_\_\_\_ Quantity \_\_\_\_\_

The TriPalm is used to illuminate objects from ground or surface mount. Constructed from CNC machined parts.

CR16 LED Lamp allows for tool free beam changes and re-lamping.

## Specification

Light Source	CR16 Led Lamp * Quick Change
LED Rated Life	50,000 hours average **
Power Consumption	5W, 8W Options
	CCT 2700K, 3000K, 4000K, 5000K
	CRI 93
Light Output	450, 640 Lumens (3000K)
Input	10-15 Vac
Lens	Borosilicate Glass
Lamp holder	GU5.3
Operating Temperature	-31F to 130F (-35C to 54C)
Maintenance	Tool Free Plug-in LED Lamp
Thermal Management	Fixture is utilized as heat sink
Fixture Construction	CNC Machined from Solid Billet
Ingress Protection	IP67
Certification	

\* IES LM-80 Standard ensures led light source will provide lumen maintenance and color performance.

\*\* LED life is defined as the time to 70% lumen maintenance (L70)

## Low Voltage Transformer Required

Ground Mount Options ( Not to Scale )

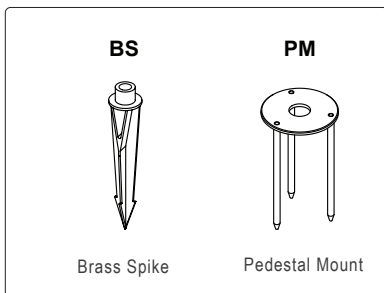

Surface Mount Options ( Not to Scale )

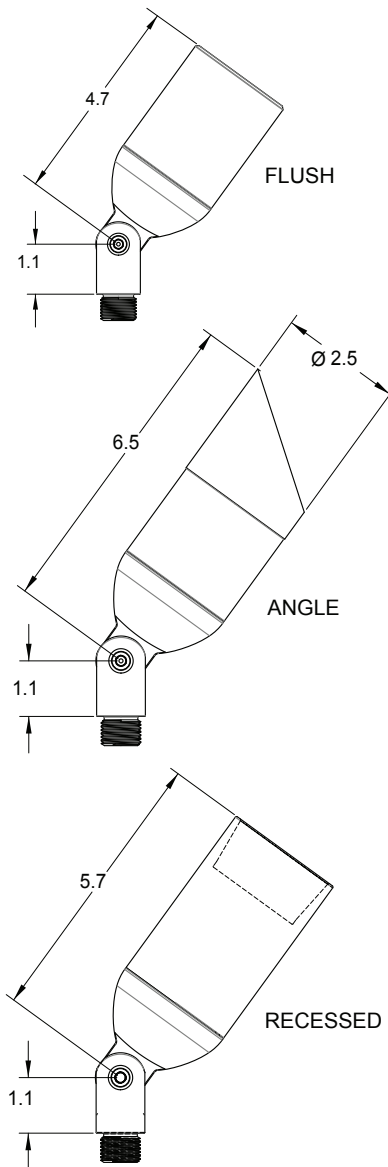
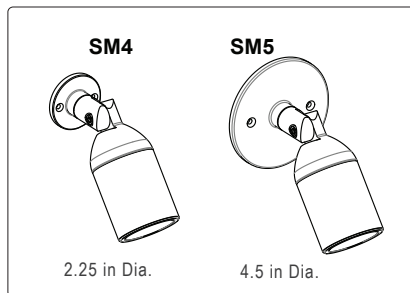

## Ordering Guide

Example: TP-BR-27-36-5-HX-00-S-PTB Brass Material, 2700K, 36 deg Beam, 5 Watt, Hex Cell, Flush Cap, 10 inch ABS stake, Patina Brown Finish

TP								
Prefix	Material	CCT	Beam	Watt	Accessory	Cap Style	Mounting	Finish
AL - Aluminum	27 - 2700K	18 - 18 deg	5 - 450 lm	00 - None	00 - Flush	S - Standard	N - Natural	
BR - Brass	30 - 3000K	25 - 25 deg	8 - 640 lm	HX - Hex Cell	01 - Angle	BS - Brass Stake	BK - Black Powder Coat	
CU - Copper	40 - 4000K	36 - 36 deg		LS - Linear	02 - Recessed	PM - Pedestal	WT - White Powder Coat	
SS - Stainless	50 - 5000K	50 - 50 deg		SF - Soft Focus		SM4 - 2.25 Round	PTB - Patina Brown (BR Only)	
						SM5 - 4.50 Round	PTK - Patina Black (BR Only)	
						ER - Riser +	C - Custom	
						AR - Adj. Riser +		
						TS - Tree Mount +		
						PP - Power Post +		

+ Specify Separately



Vista, CA 92081 www.dglights.com info@dglights.com

